

LGK Grupa Kęty

• Aesthetically pleasant appearance

• Reduced on site installation

• Cost effective

Structurally Silicone
Glazed Curtain Wall

MB-SG50

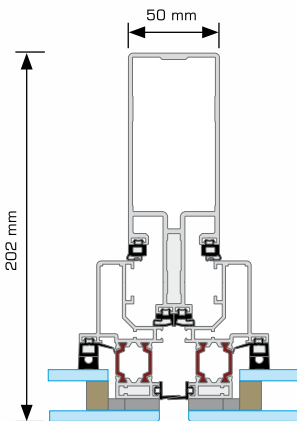

Mullion cross-section

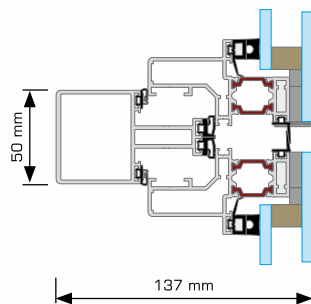

Transom cross-section

The MB-SG50 system enables to build curtain walls with glazing without the visible aluminum face caps giving an impression of glassy surface from the outside. They come as prefabricated units from the manufacturing site which ensures quality and reduces on site assembly.

MB-SG50



MB-SG50 base system variety features glazing units integrated together with the use of silicone sealant. The system carries thermal barrier and triple insulation system of gaskets that provide enhanced thermal insulation as well as watertightness and air permeability.

MB-SG50 SEMI

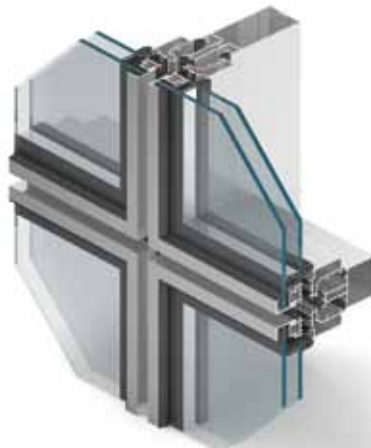

The MB-SG50 SEMI variety features key benefits of structural glazed curtain wall and at the same time offers delicate picture frame look when viewed externally.



FEATURES AND BENEFITS

- aesthetically pleasant appearance - the gap between glazing unit is 16 mm.
- front glass joint silicone sealed
- tilt window does not affect the appearance
- mullion drainage

TECHNICAL SPECIFICATION

MB-SG50 / MB-SG50 SEMI

Size and width

Depth mullions	85 - 125 mm
Depth transoms	45 - 105 mm
Inertia mullions	81,06 - 315,40 cm ⁴
Inertia transoms	35,06 - 166,45 cm ⁴
Glazing thickness	28-32 mm

PERFORMANCE

MB-SG50 / MB-SG50 SEMI

Air Permeability	Class A4 (600Pa) EN 12153:2002U; EN 12152:2002U	
Windload resistance	1430 Pa EN 12179:2002U; EN 13116:2002U	1637Pa EN 12179:2002U; EN 13116:2002U
Watertightness	Class R7 (300Pa) EN 12155:2002U; EN 12154:2002U	
Thermal Insulation (U _{TJ})	It is measured individually and depends upon profile's combination	